

PIN L304

Mastelygte / Mast lamp / Mastleuchte / Mast lampa

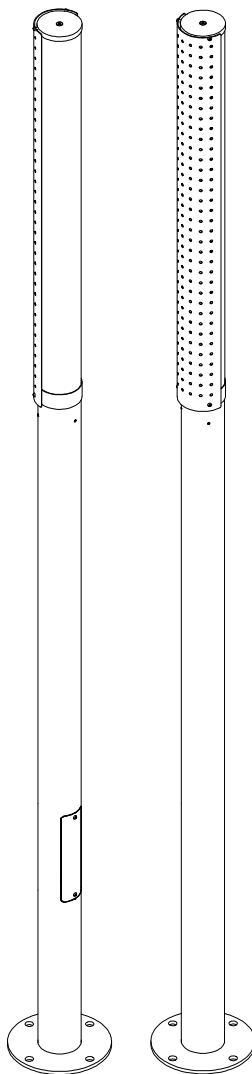

Monteringsvejledning / Mounting instructions /
Installationsanleitung / Installationsinstruktioner

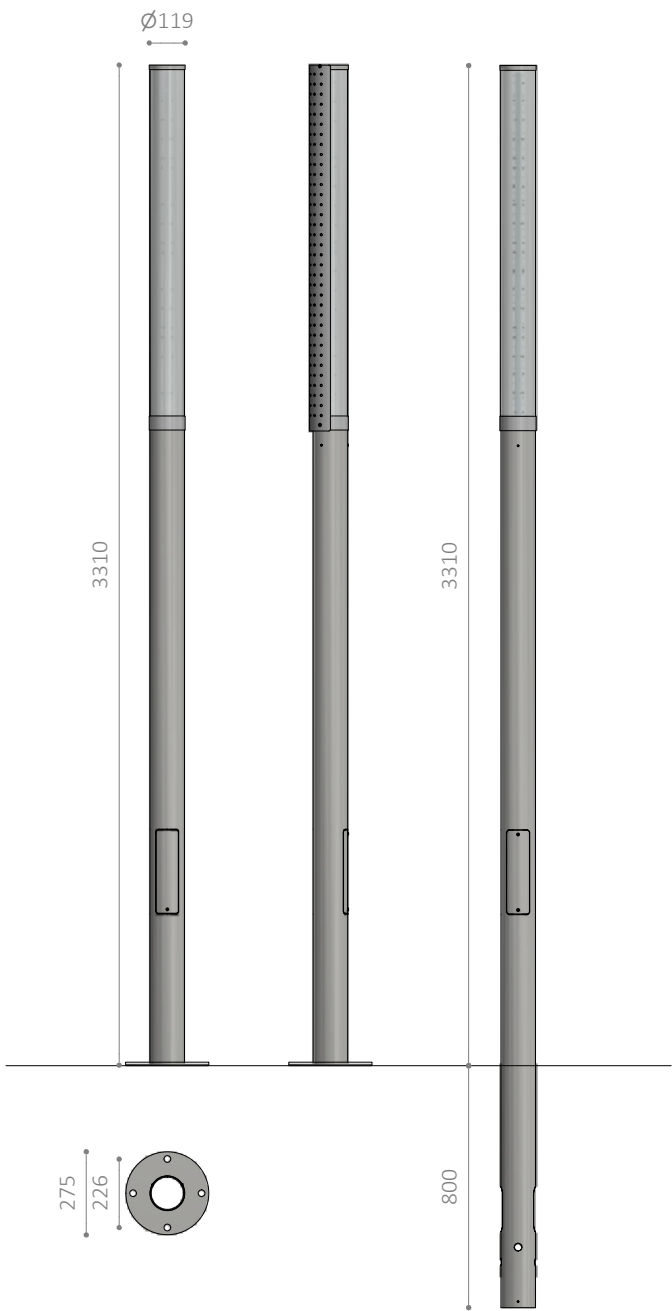

Værktøj / Tool /
Werkzeug / Verktyg:

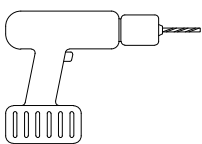

3/4 mm

1



4 mm

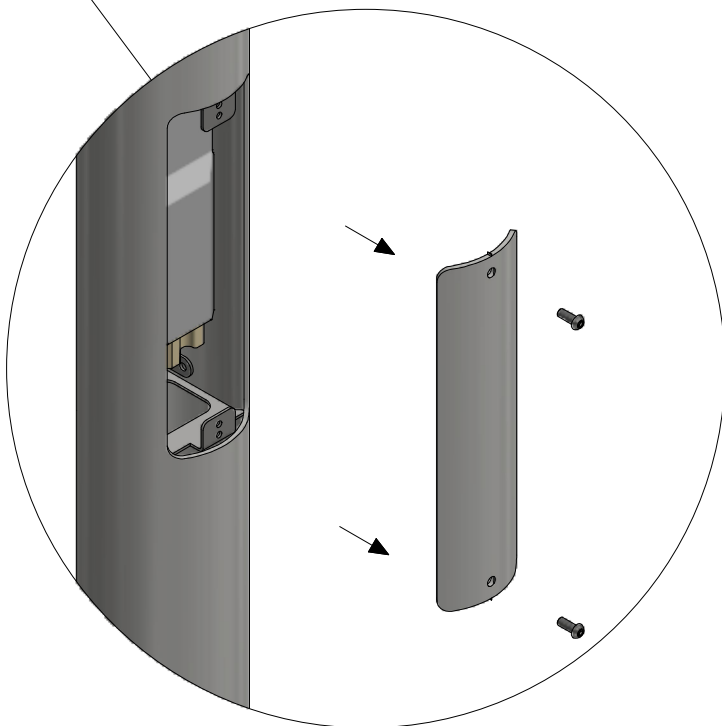
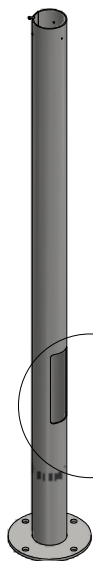

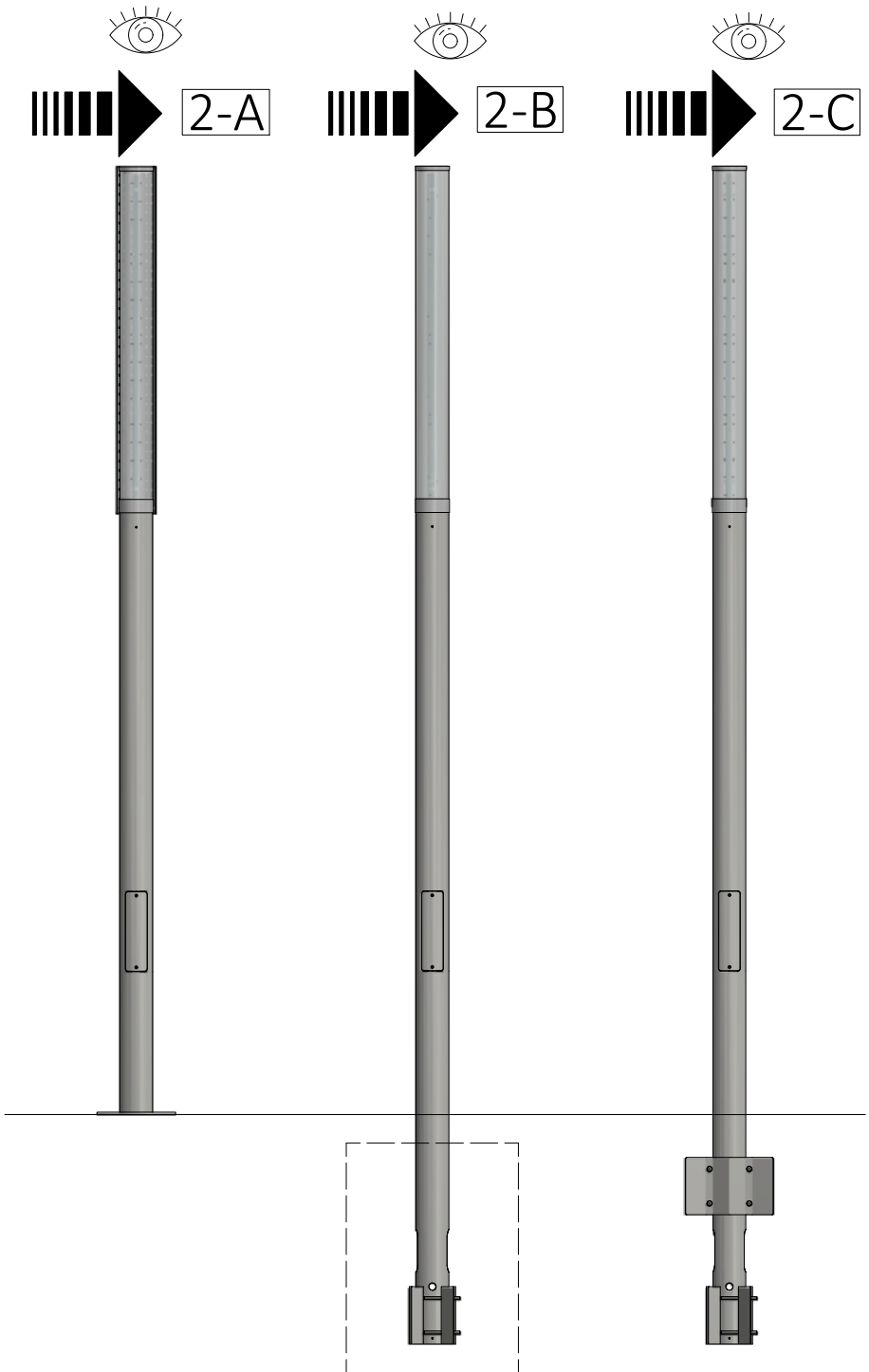

2-A

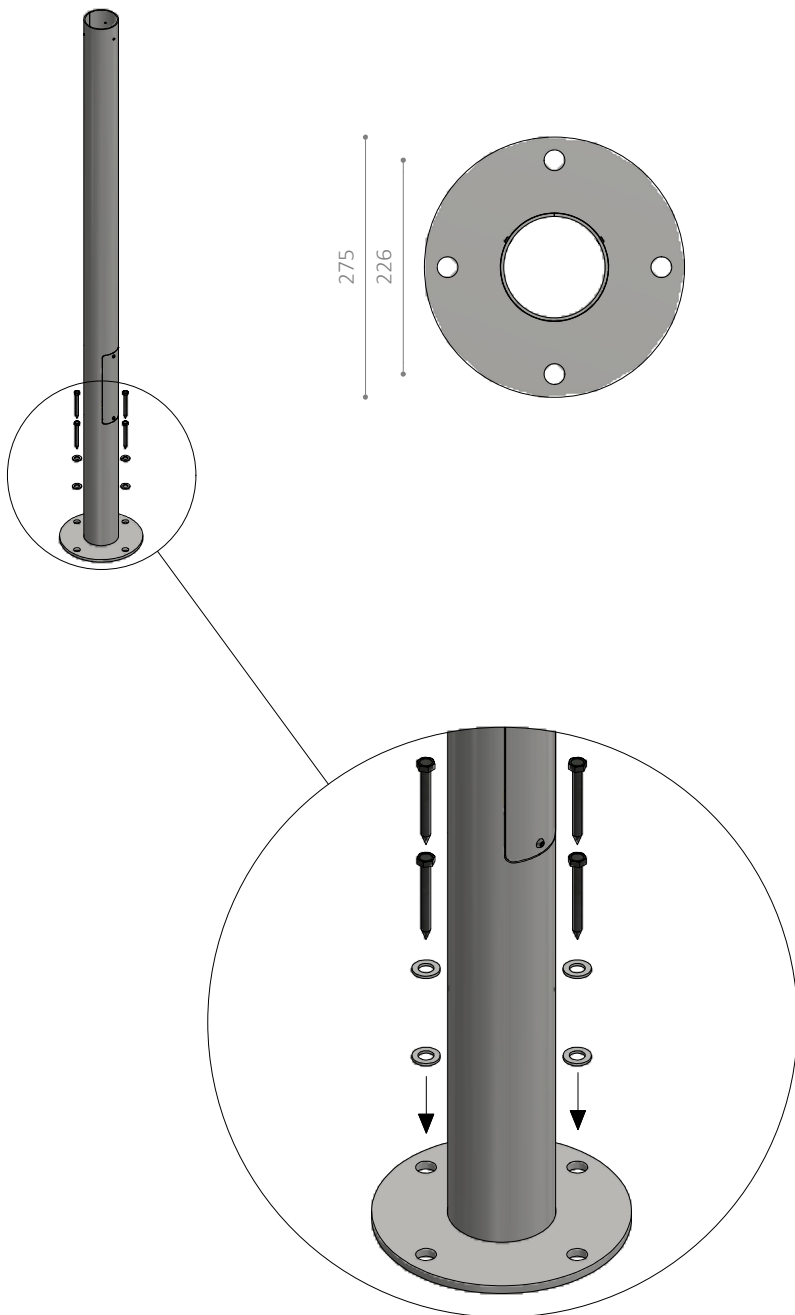

2-B

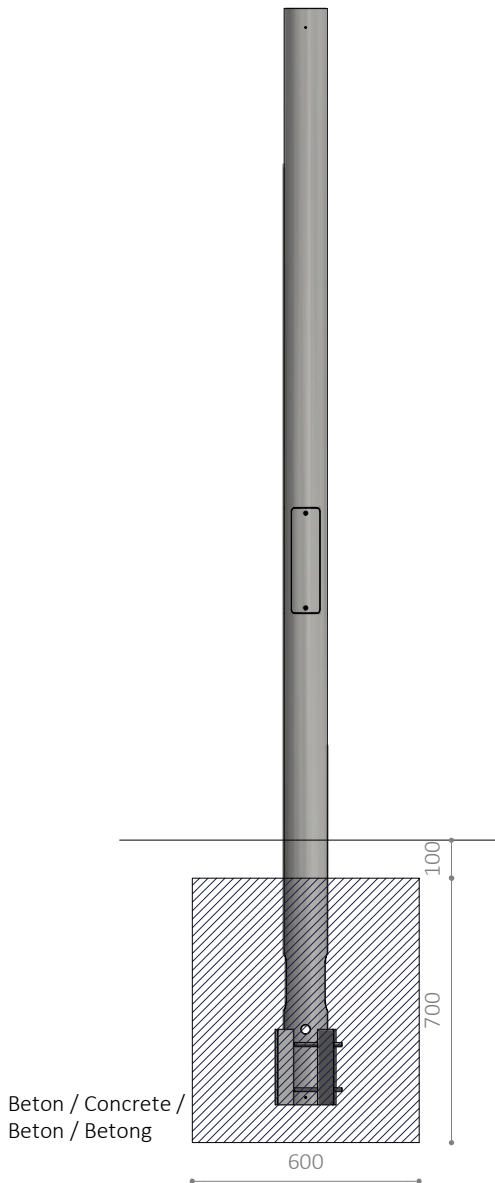

Se monteringsvejledning / See mounting instructions / Siehe
Installationsanleitung / Se Installationsinstruktioner nr. 19651000-96

2-C

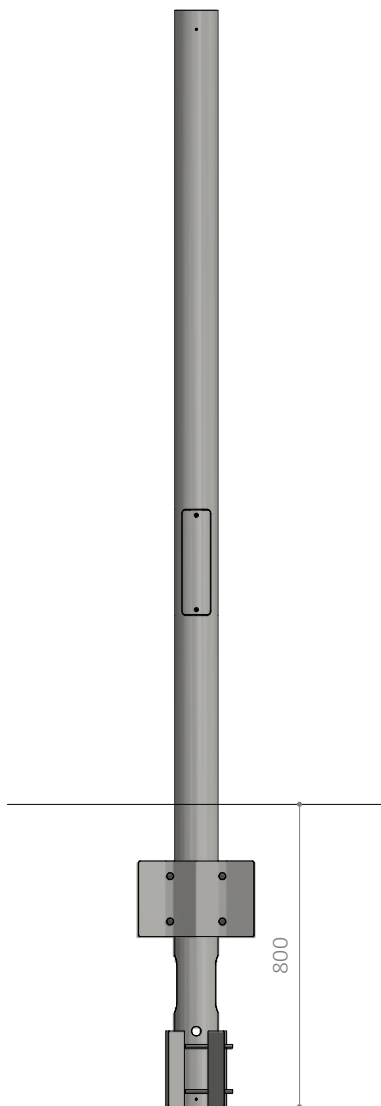

Se monteringsvejledning / See mounting instructions / Siehe
Installationsanleitung / Se Installationsinstruktioner nr. 19651000-96

3

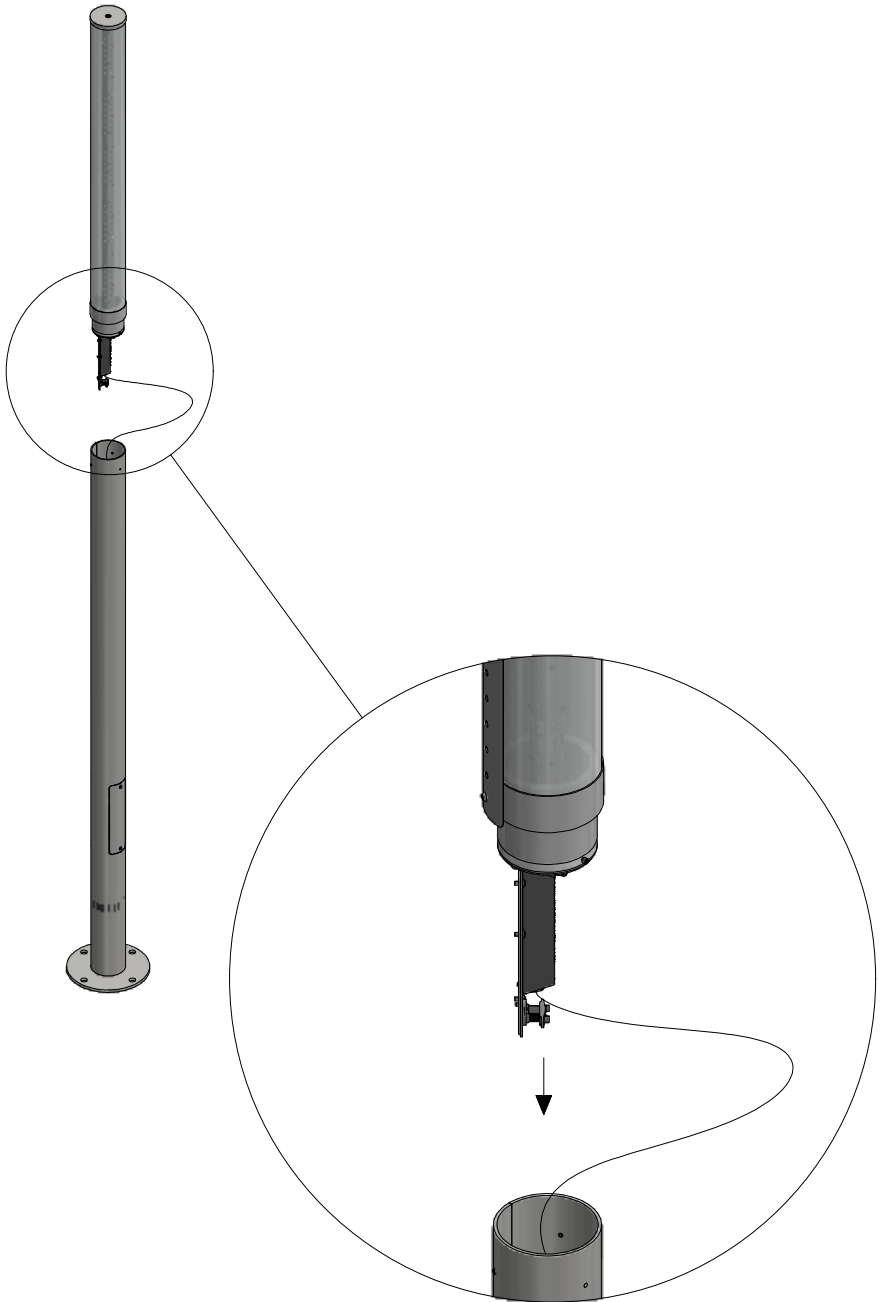

4



3 mm

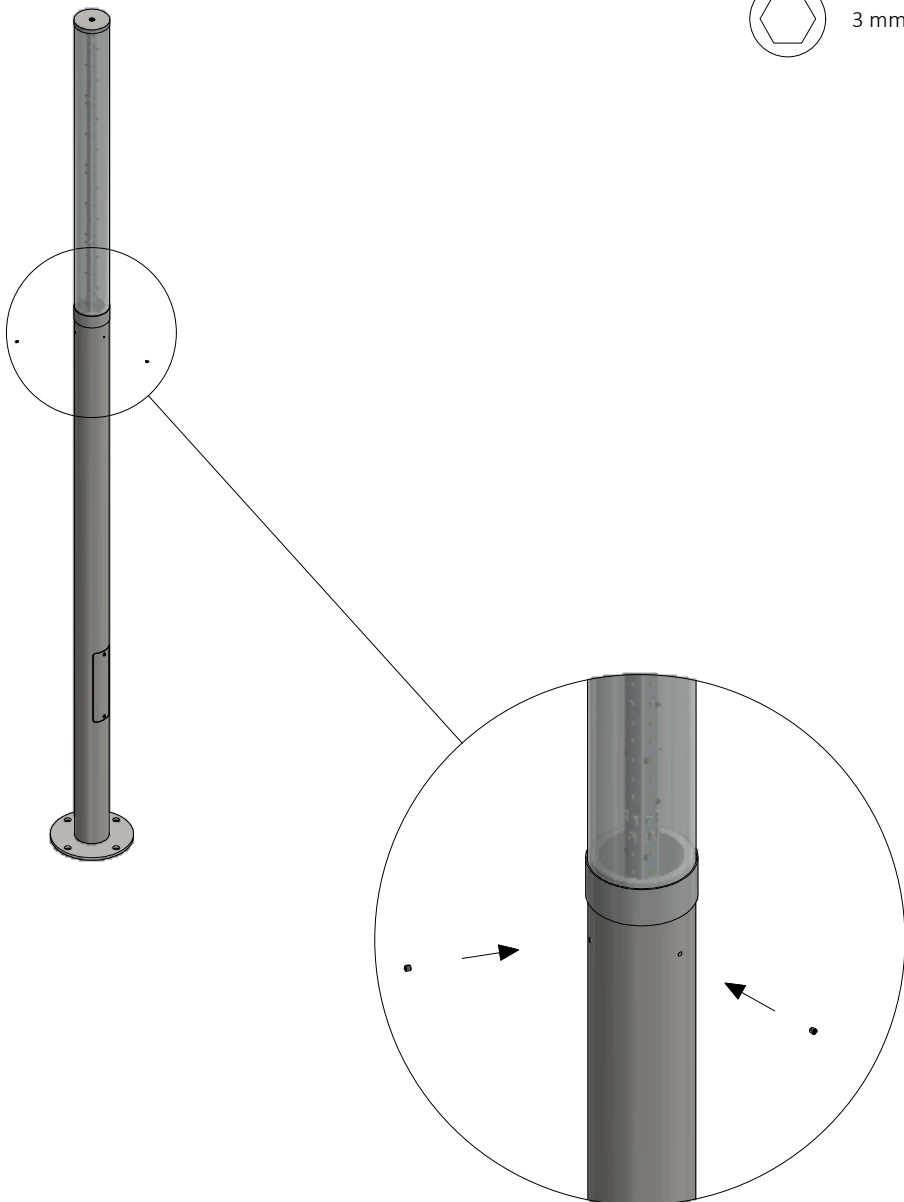

5

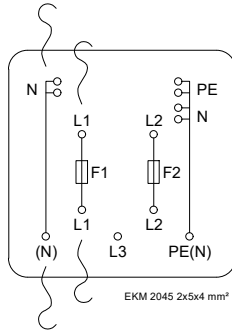
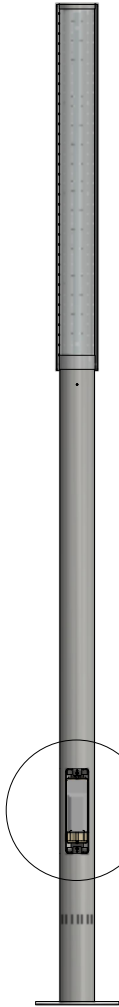

Isolationsklasse II / Insulation class II /
Schutzklasse II / Isolationsklass II

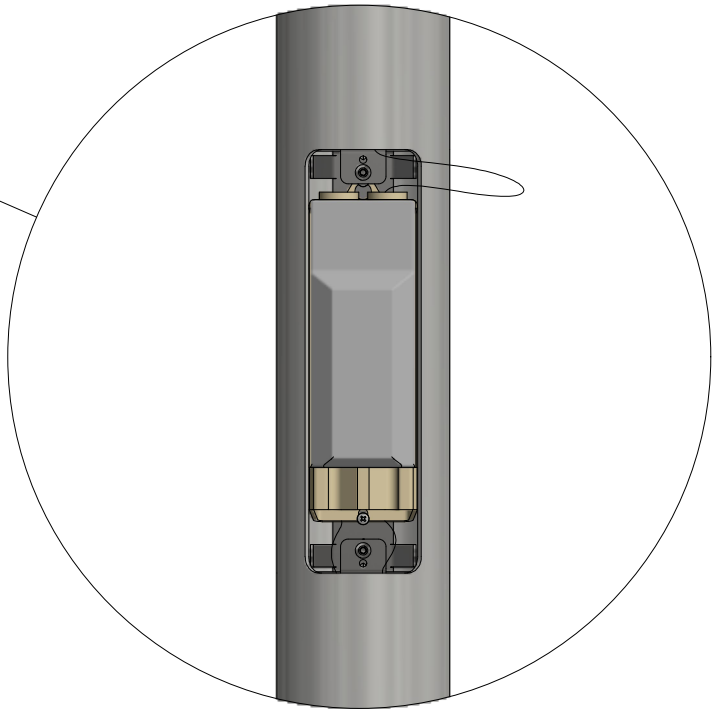







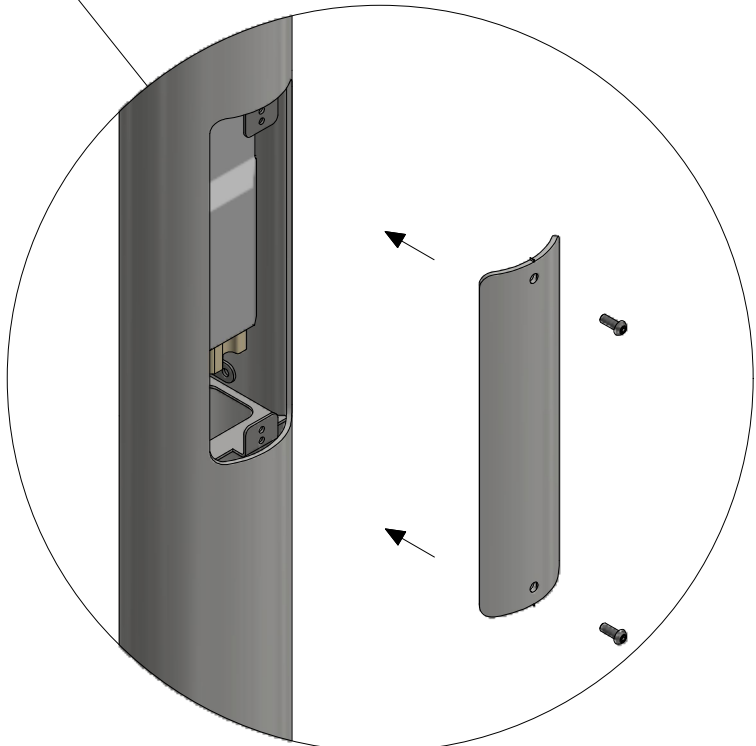
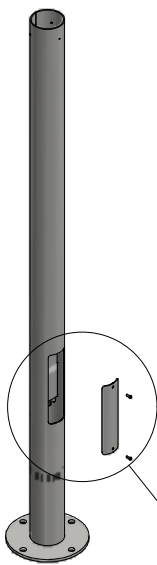



6



3 mm



			
	LED		
	Isolationsklasse II / Insulation class II / Schutzklasse II / Isolationsklass II		
	IP56		
IK	IK10		
	45 kg		
	Se vedligeholdelses vejledning / See maintenance instructions / Siehe Wartungsanweisungen / Se underhållsinstruktioner		
	<p>Montering/udskiftning må kun udføres af producenten eller aut. el-installatør / Installation/replacement must only be carried out by the manufacturer or by an electrician / Die Installation/der Austausch darf nur vom Hersteller oder von einem Elektriker durchgeführt werden / Installation / utbyte får endast utföras av tillverkaren eller av en behörig elektriker</p>		